

NOTES: (UNLESS OTHERWISE SPECIFIED)

1. Mating according to IEC169-9.
2. After crimping dimension should be SW3.25
3. Part must be packaged to avoid any damages during transportation.

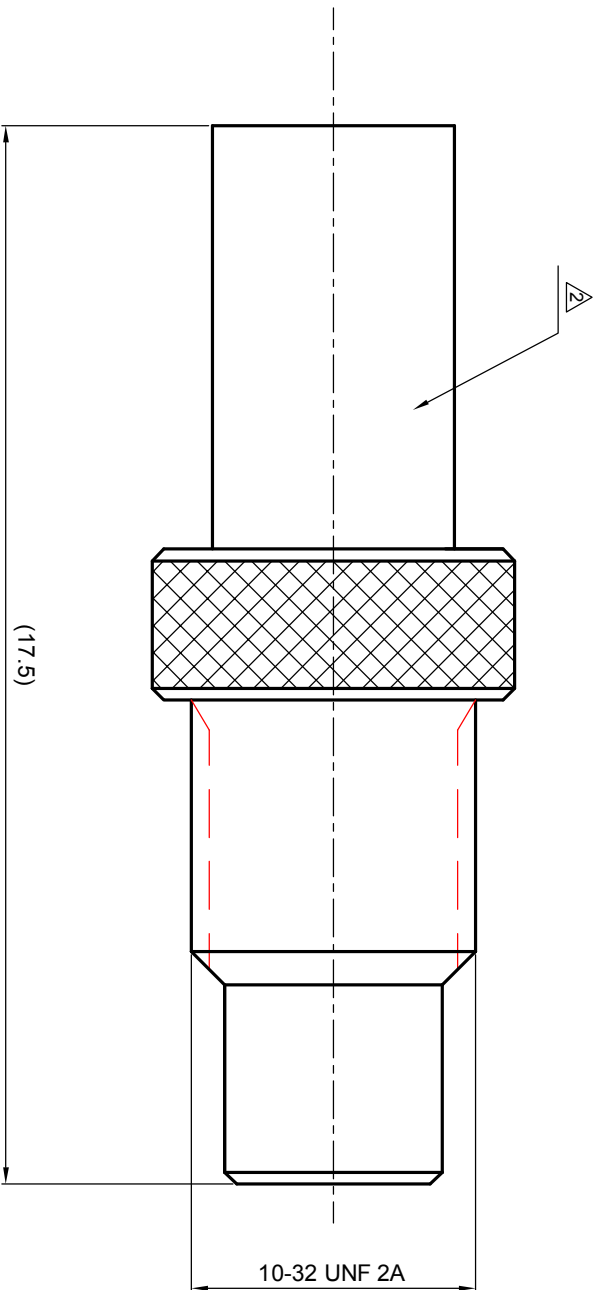

RECOMMENDED CABLE
STRIPPING DIMENSIONS

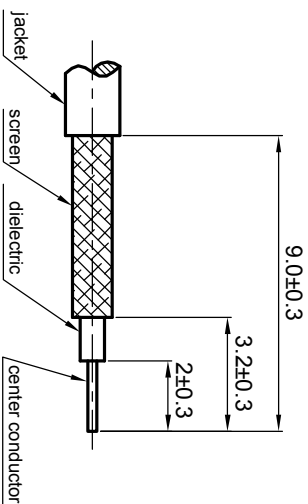

REV.	DESCRIPTION	APPROVED	DATE	EON

MATERIAL		SEE BOM		THIRD ANGLE PROJECTION		TITLE	
FINISH		SEE BOM				SMC, PLUG, CABLE	
TOLERANCES		Opface X ±1 1place X ±0.1 2place XX ±0.05 Angle ±5°		GENERAL ECCENTRICITY <input checked="" type="checkbox"/> Z1003		DWG. NO.	
Remove burrs and sharp edges				DRAWN BY COLIN		5312.SMC.PSC.06.111	
Plating part to be touched by gloves		Dimension apply before plating		DATE 19Aug08		REV.	
Dimension apply before plating		XXX - measuring point for plating		CHECKED BY		S1	
SURFACE		VOLUME		APPROVED BY		SCALE	
						8:1	
						DO NOT SCALE DRAWING	
						SIZE	
						A4	
						SHEET	
						1 of 1	

Zee-teq

1.6

1 2 3 4 5 6