

NOTES: (UNLESS OTHERWISE SPECIFIED)

1. Interface according to IEC 169-4
2. With a protective cap.
3. Part must be packaged to avoid any damages during transportation.

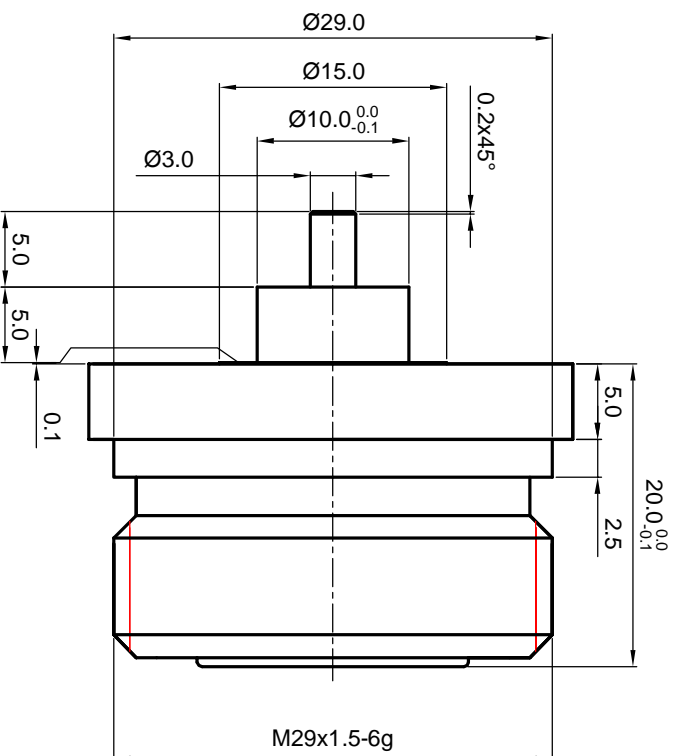
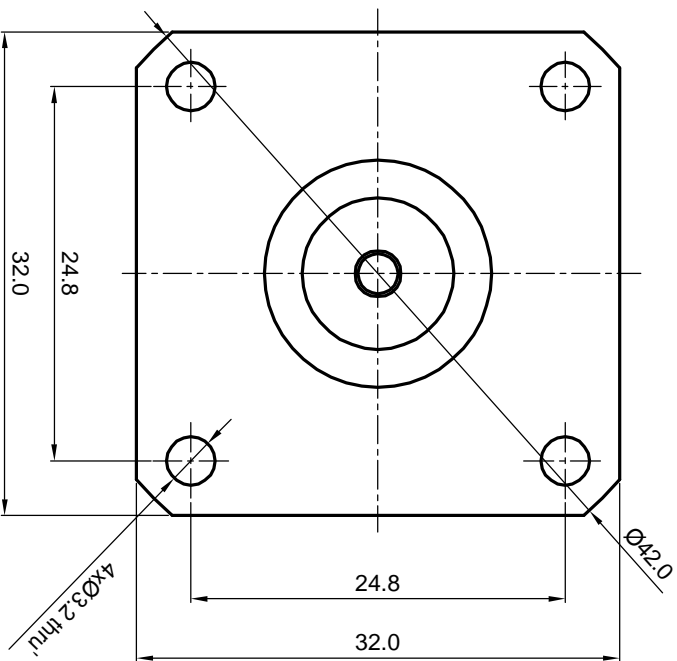

1.6

REV.	DESCRIPTION	APPROVED	DATE	ECN

MATERIAL		SEE BOM		TOLERANCES		THIRD ANGLE PROJECTION		TITLE	
FINISH		SEE BOM		Opface X ±1 1place X ±0.1 2place XX ±0.05 Angle ±5°				BODY Zeeteq	
Plating part to be touched by gloves		Remove burrs and sharp edges		±0.1 ±0.1		GENERAL ECCENTRICITY <input checked="" type="checkbox"/> 100%		DWG. NO. 6055.716.JSF.00.230	
Dimension apply before plating				DRAWN BY		NAME		DATE	
XXX - measuring point for plating				CHECKED BY		Colin		06Sep07	
SURFACE		VOLUME		APPROVED BY				SCALE	
								2:1	
								DO NOT SCALE DRAWING	
								SIZE	
								A4	
								SHEET	
								1 of 1	
								REV.	
								S1	

NOTICE: Those drawings and specifications are the property of ZEETEQ CORPORATION and used only for the specify purpose authorised by ZEETEQ

1 2 3 4 5 6