

**NOTES: (UNLESS OTHERWISE SPECIFIED)**

1. Interface according to IEC 169-4
2. With a protective cap.
3. Part must be packaged to avoid any damages during transportation.

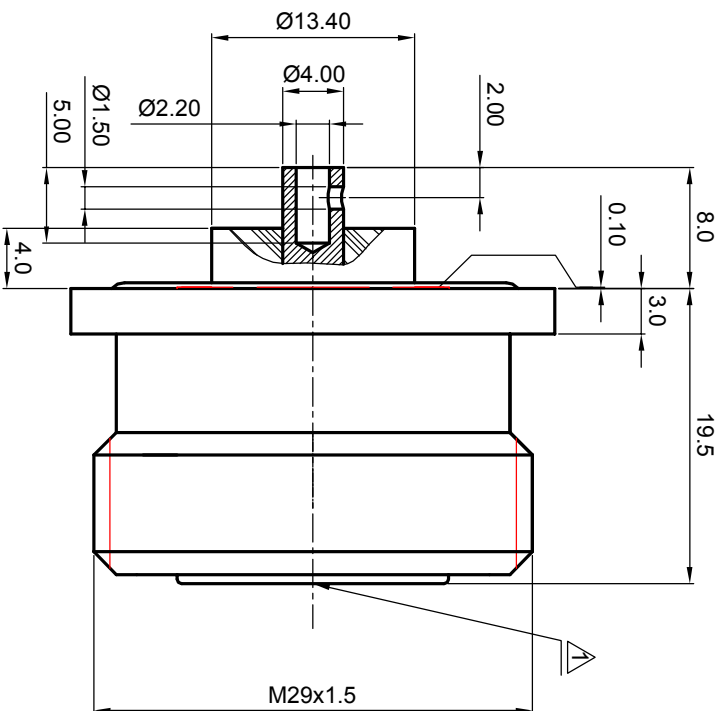
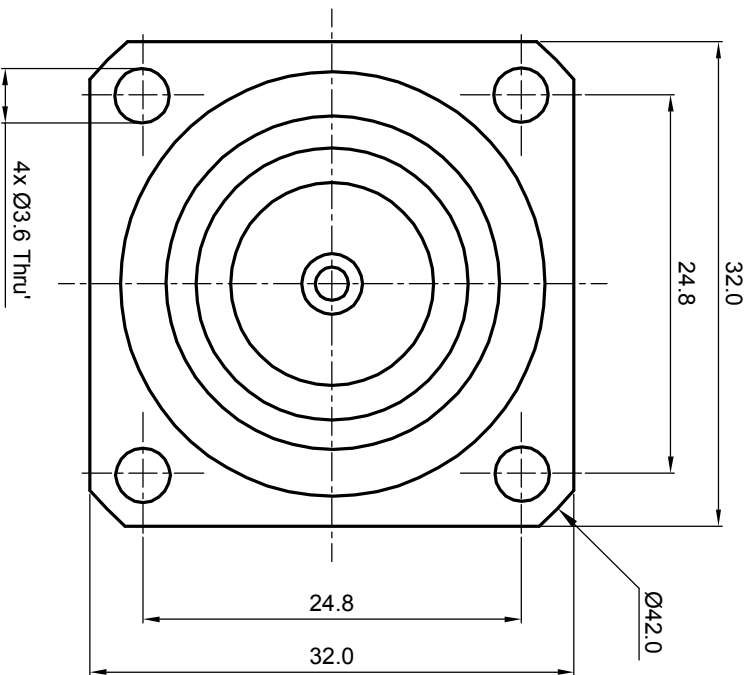

REV.	DESCRIPTION	APPROVED	DATE	EON
A	Rel to production	Johnny	21Sep07	
B	B3-B4: add O-ring slot	Colin	29Apr08	ECN_08_012

MATERIAL <b>SEE BOM</b>		THIRD ANGLE PROJECTION		TITLE <b>7/16, JACK, FLANGE</b>	
FINISH <b>SEE BOM</b>		GENERAL ECCENTRICITY <input checked="" type="checkbox"/> 100%		DWG NO. <b>6069.716.JSF.00.230</b>	
TOLERANCES Opface X ±1 1place X ±0.1 2place .XX ±0.05 Angle ±5°		DRAWN BY Colin		DATE 14Sep07	
Remove burrs and sharp edges		CHECKED BY		APPROVED BY	
Plating part to be touched by gloves		NAME		REV. <b>B</b>	
Dimension apply before plating		DATE		SCALE 2:1	
XXX - measuring point for plating		APPROVED BY		DO NOT SCALE DRAWING	
SURFACE		VOLUME		SIZE A4	
1		2		3	
4		5		6	

**Zeeteq**

1.6

A

A

B

B

C

C

1

2

3

4

5

6

1

2

3

4

5

6