

**NOTES: (UNLESS OTHERWISE SPECIFIED)**

- Interface comply with IEC 169-4.
- Part must be packaged to avoid any damages during transportation.

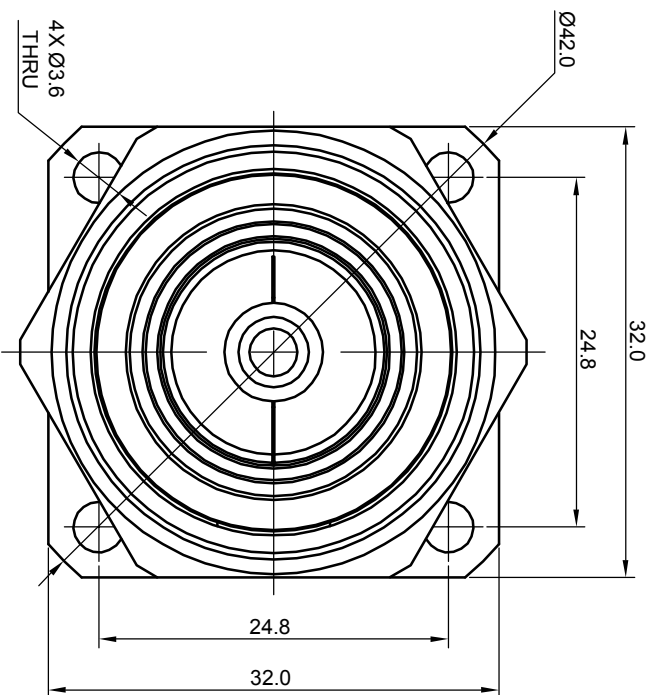
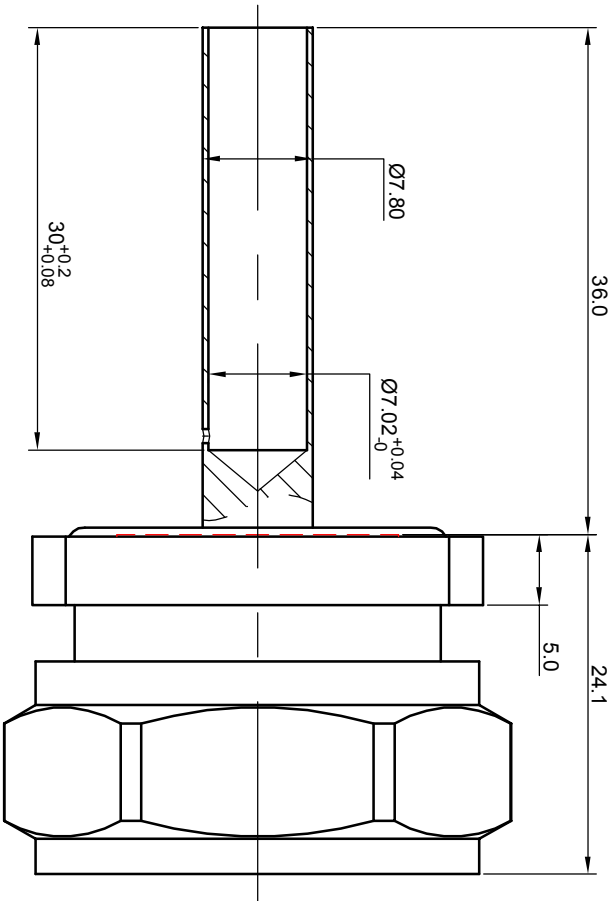

REV.	DESCRIPTION	APPROVED	DATE	ECN
A	Rel to production	Johnny	18Feb08	
B	Changed dim Ø7 <sup>+0.05</sup> to Ø7.02 <sup>+0.04</sup> in zone B3; added a hole in zone c3.	Joy Zhou	27Feb08	ECN_08_005

MATERIAL SEE BOM FOR DETAILS		TOLERANCES		THIRD ANGLE PROJECTION		Zee-teq	
FINISH SEE BOM FOR DETAILS		Optace X ±1 1place X ±0.1 2place .XX ±0.05 Angle ±5°		GENERAL ECCENTRICITY <input checked="" type="checkbox"/> 0.06		TITLE 716, PLUG, FLANGE	
Plating part to be touched by gloves		Remove burrs and sharp edges		DRAWN BY Joy Zhou 08Aug07		DWG NO. 6035.716.PSF.00.233	
Dimension apply before plating				CHECKED BY		SCALE 5:1	
XXX - measuring point for plating		APPROVED BY		NAME DATE		DO NOT SCALE DRAWING	
SURFACE		VOLUME		NOTICE: Those drawings and specifications are the property of ZEE-TEQ CORPORATION and used only for the specify purpose authorised by ZEE-TEQ		SIZE A4	
						SHEET 1 of 1	

