

- NOTES: (UNLESS OTHERWISE SPECIFIED)**
- Interface comply with IEC 169-16.
 - Part must be packaged to avoid any damages during transportation.

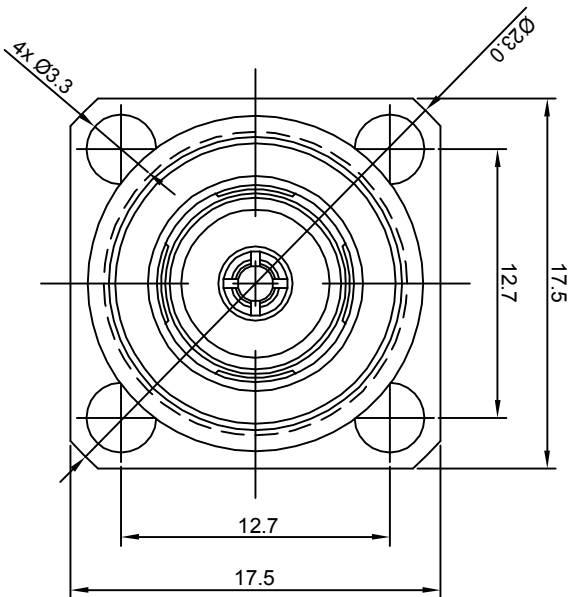
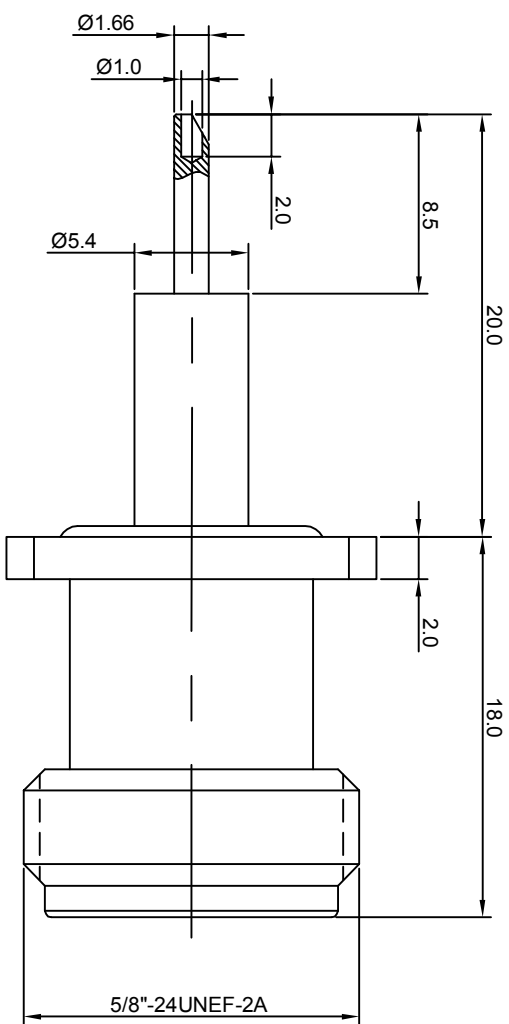

1.6

REV.	DESCRIPTION	APPROVED	DATE	ECN
A	Rel To Production	Johnny	18Jan08	

MATERIAL SEE BOM FOR DETAILS		THIRD ANGLE PROJECTION		TITLE Zeeteq											
FINISH SEE BOM FOR DETAILS		<table border="1"> <tr> <td>Optimize</td> <td>X ±1</td> </tr> <tr> <td>1place</td> <td>X ±0.1</td> </tr> <tr> <td>2place</td> <td>.XX ±0.05</td> </tr> <tr> <td>Angle</td> <td>±5°</td> </tr> </table>		Optimize	X ±1	1place	X ±0.1	2place	.XX ±0.05	Angle	±5°	GENERAL ECCENTRICITY		DWG NO. 6029.N.JSF.00.150	
Optimize	X ±1														
1place	X ±0.1														
2place	.XX ±0.05														
Angle	±5°														
Plating part to be touched by gloves		<table border="1"> <tr> <td>NAME</td> <td>DATE</td> </tr> <tr> <td>Joy Zhou</td> <td>13Aug07</td> </tr> </table>		NAME	DATE	Joy Zhou	13Aug07	SCALE 3:1							
NAME	DATE														
Joy Zhou	13Aug07														
Dimension apply before plating		DRAWN BY		DO NOT SCALE DRAWING											
XXX - measuring point for plating		CHECKED BY		SIZE A4											
SURFACE		APPROVED BY		SHEET 1 of 1											
VOLUME		<table border="1"> <tr> <td>NOTICE:</td> <td>Those drawings and specifications are the property of ZEEETEQ CORPORATION and used only for the specify purpose authorised by ZEEETEQ</td> </tr> </table>		NOTICE:	Those drawings and specifications are the property of ZEEETEQ CORPORATION and used only for the specify purpose authorised by ZEEETEQ	REV. A									
NOTICE:	Those drawings and specifications are the property of ZEEETEQ CORPORATION and used only for the specify purpose authorised by ZEEETEQ														

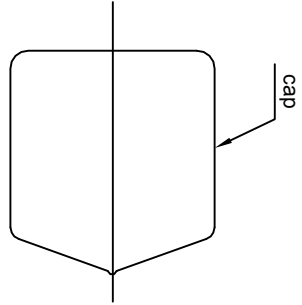

1 2 3 4 5 6