

NOTES: (UNLESS OTHERWISE SPECIFIED)

1. Interface according to IEC:169-16.
2. With a protective cap.
3. Part must be packaged to avoid any damages during transportation.

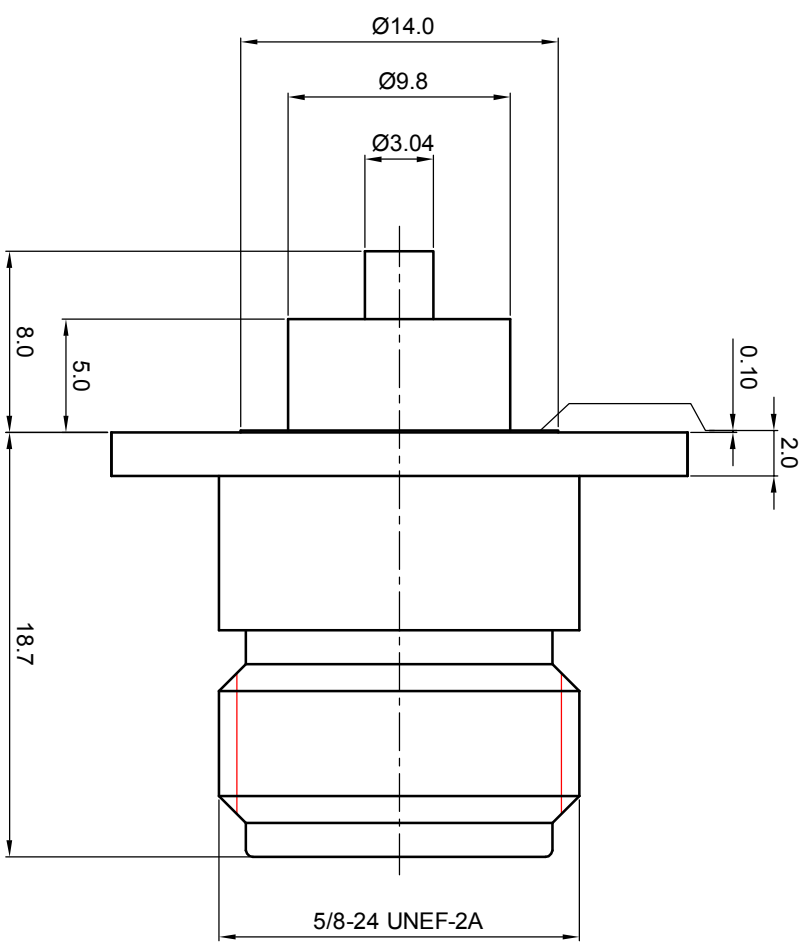
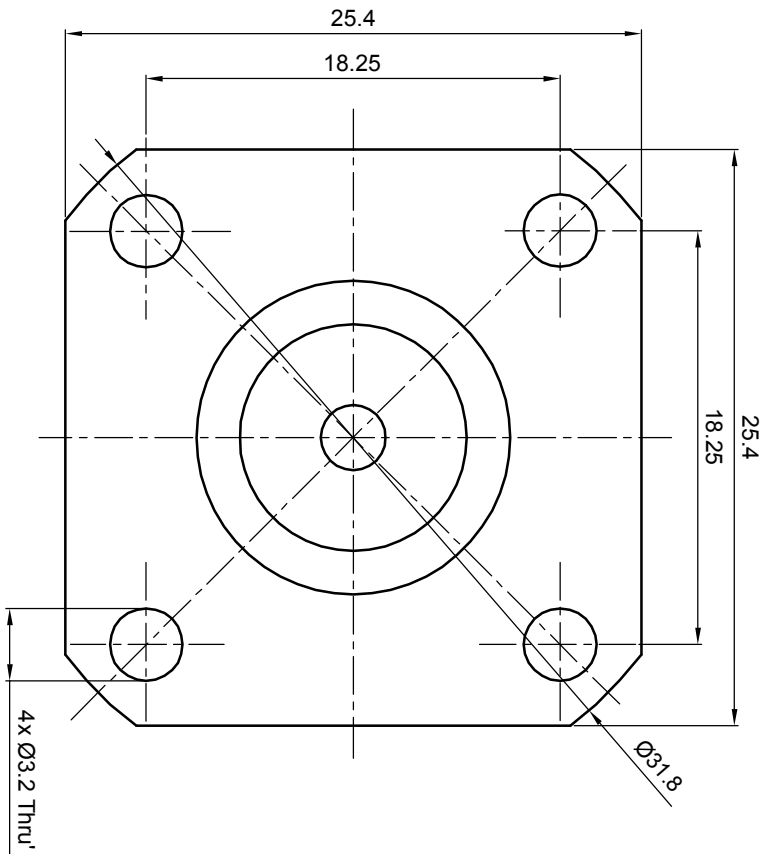

REV.	DESCRIPTION	APPROVED	DATE	EON
A	Rel to production	Johnny	08Aug08	ECN_08_044

MATERIAL		SEE BOM		THIRD ANGLE PROJECTION		TITLE	
FINISH		SEE BOM		GENERAL ECCENTRICITY		N, JACK, FLANGE	
TOLERANCES		Opface X ±1 1place .X ±0.1 2place .XX ±0.05 Angle ±5°		NAME		DWG NO.	
Remove burrs and sharp edges				DATE		6102.N.JSF.00.130	
Plating part to be touched by gloves		DRAWN BY		CHECKED BY		SCALE	
Dimension apply before plating		Colin		APPROVED BY		3:1	
XXX - measuring point for plating		20Nov07				DO NOT SCALE DRAWING	
SURFACE		VOLUME				SIZE	
						A4	
						SHEET	
						1 of 1	
						REV.	
						A	

