

NOTES: (UNLESS OTHERWISE SPECIFIED)

1. Interface according to IEC 169-15
2. With a protective cap.
3. Part must be packaged to avoid any damages during transportation.

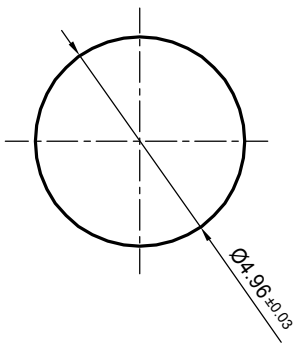
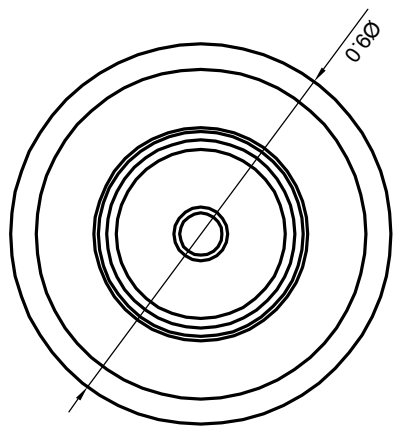
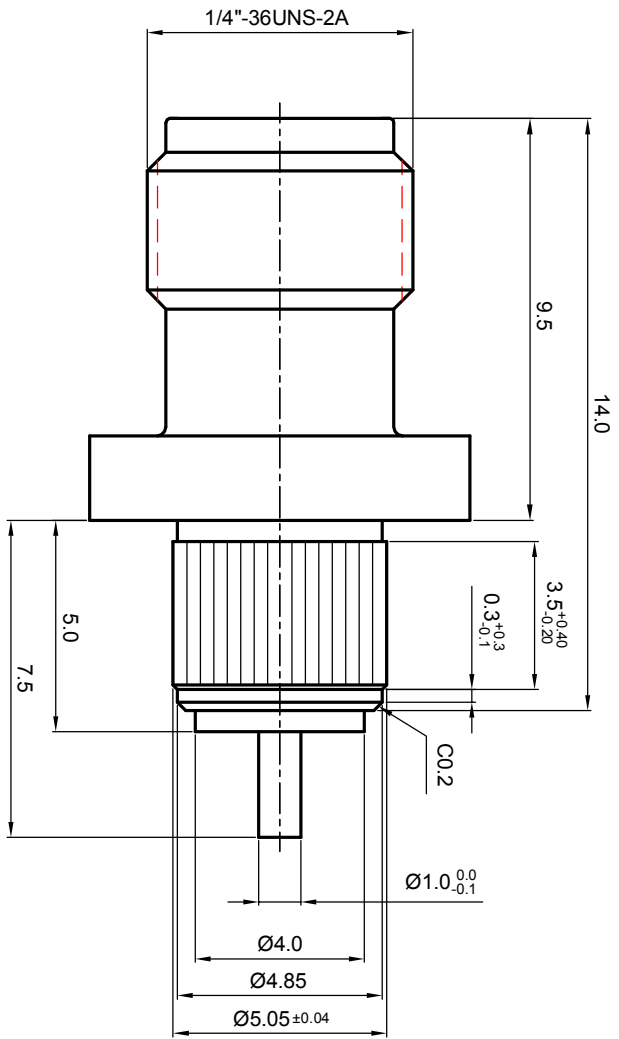

REV.	DESCRIPTION	APPROVED	DATE	ECN
A	Rel to production	Johnny	11Sep07	

MATERIAL		THIRD ANGLE PROJECTION		TITLE	
SEE BOM					
FINISH		TOLERANCES		DRAWN BY	
SEE BOM		Oplate X ±1 1place X ±0.1 2place .XX ±0.05 Angle ±5°		Colin 08Aug07	
Plating part to be touched by gloves		Remove burrs and sharp edges		CHECKED BY	
Dimension apply before plating				Joy Zhou 09Aug07	
XXX - measuring point for plating		GENERAL ECCENTRICITY $\sqrt{1000}$		APPROVED BY	
SURFACE		NOTICE: Those drawings and specifications are the property of ZEETEQ CORPORATION and used only for the specify purpose authorised by ZEETEQ		Johnny 09Aug07	
VOLUME		SCALE		DWG NO.	
		2:1 DO NOT SCALE DRAWING		6037.SMA.JSP.00.110	
		SIZE		REV.	
		A4		A	
		SHEET		1 of 1	

