

**NOTES: (UNLESS OTHERWISE SPECIFIED)**

1. Interface according to IEC 169-15
2. With a protective cap.
3. Part must be packaged to avoid any damages during transportation.

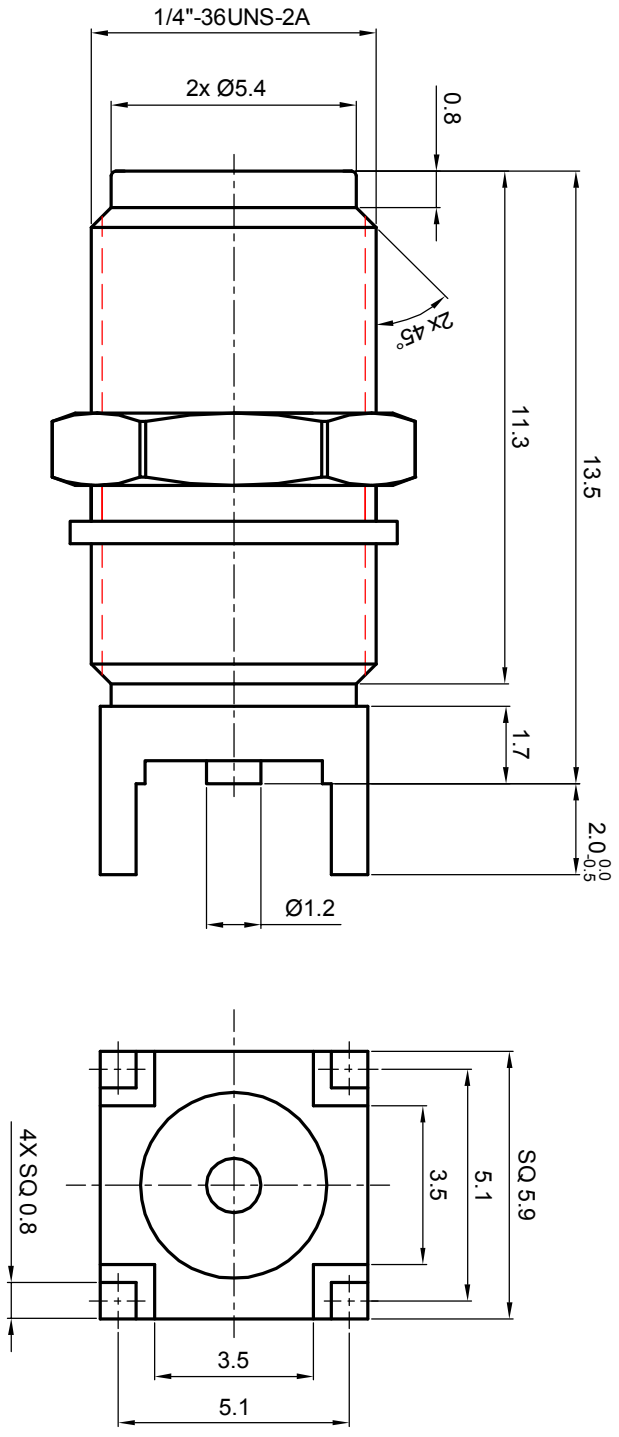

1	2	3	4	5	6
---	---	---	---	---	---

REV.	DESCRIPTION	APPROVED	DATE	ECN
A	Rel to production	Johnny	21Sep07	
B	A4: change 3 -0.5 to 2 -0.5	Colin	27Nov07	ECN_07_009

MATERIAL <b>SEE BOM</b>		TOLERANCES Opface X ±1 1place .X ±0.1 2place .XX ±0.05 Angle ±5°		THIRD ANGLE PROJECTION 	
FINISH <b>SEE BOM</b>		Remove burrs and sharp edges 		GENERAL ECCENTRICITY <input checked="" type="checkbox"/> Z1008	
Plating part to be touched by gloves		DRAWN BY	NAME	DATE	
Dimension apply before plating		COLIN	WALTER	12Sep07	
XXX - measuring point for plating		CHECKED BY	JOHNNY	27Nov07	
SURFACE		APPROVED BY			
VOLUME		JOHNNY		27Nov07	
<p><b>NOTICE:</b> Those drawings and specifications are the property of ZEETEQ CORPORATION and used only for the specify purpose authorised by ZEETEQ</p>					
TITLE <b>SMA, JACK, PCB</b>			DWG NO. <b>6061.SMA.JST.00.111</b>		
SCALE 2:1			DO NOT SCALE DRAWING		SIZE A4
REV. <b>B</b>			SHEET 1 of 1		

1	2	3	4	5	6
---	---	---	---	---	---

