

- NOTES: (UNLESS OTHERWISE SPECIFIED)**
- Interface comply with IEC 169-15.
 - Part must be packaged to avoid any damages during transportation.

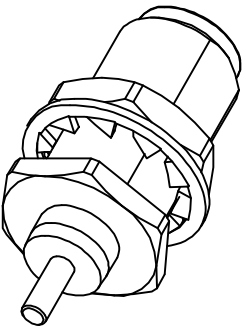
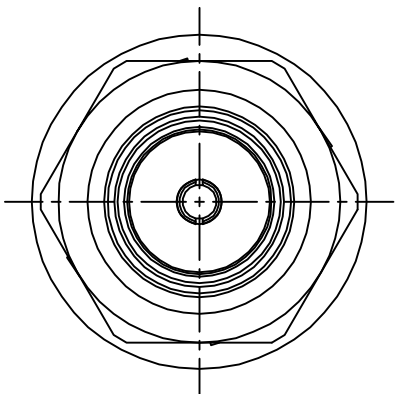
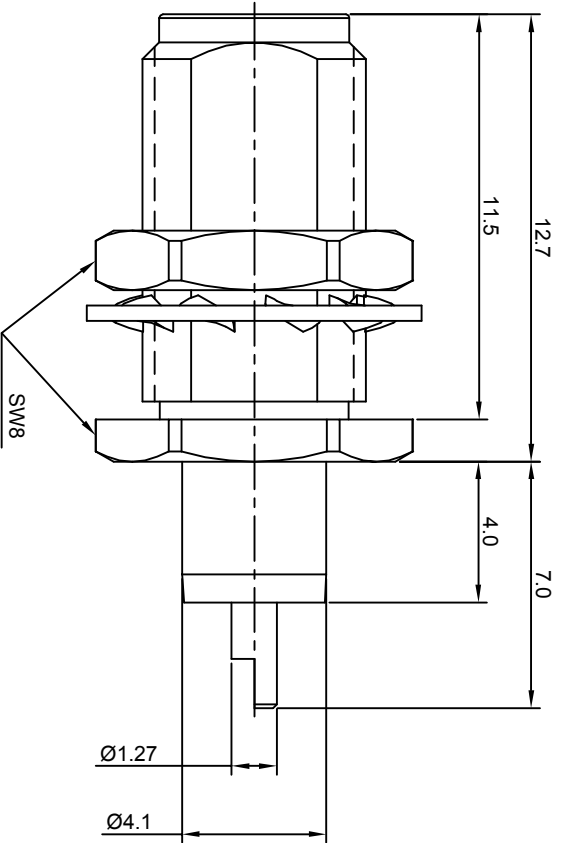

REV.	DESCRIPTION	APPROVED	DATE	ECN

MATERIAL SEE BOM FOR DETAILS	
FINISH SEE BOM FOR DETAILS	
Plating part to be touched by gloves	
Dimension apply before plating	
XXX - measuring point for plating	
SURFACE	VOLUME

TOLERANCES	
1place	X ±1
2place	X ±0.1
Angle	.XX ±0.05
Remove burrs and sharp edges	±5°

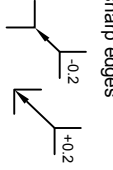

THIRD ANGLE PROJECTION	
GENERAL ECCENTRICITY $\sqrt{0.06}$	
DRAWN BY	NAME
JOY ZHOU	JOY ZHOU
CHECKED BY	DATE
	14AUG07
APPROVED BY	

TITLE	
Zeeteq	
SMA, JACK, BULKHEAD	
DWG. NO.	REV.
5970.SMA.JSB.00.111	S1
SCALE	SIZE
5:1	A4
DO NOT SCALE DRAWING	SHEET
	1 of 1

