

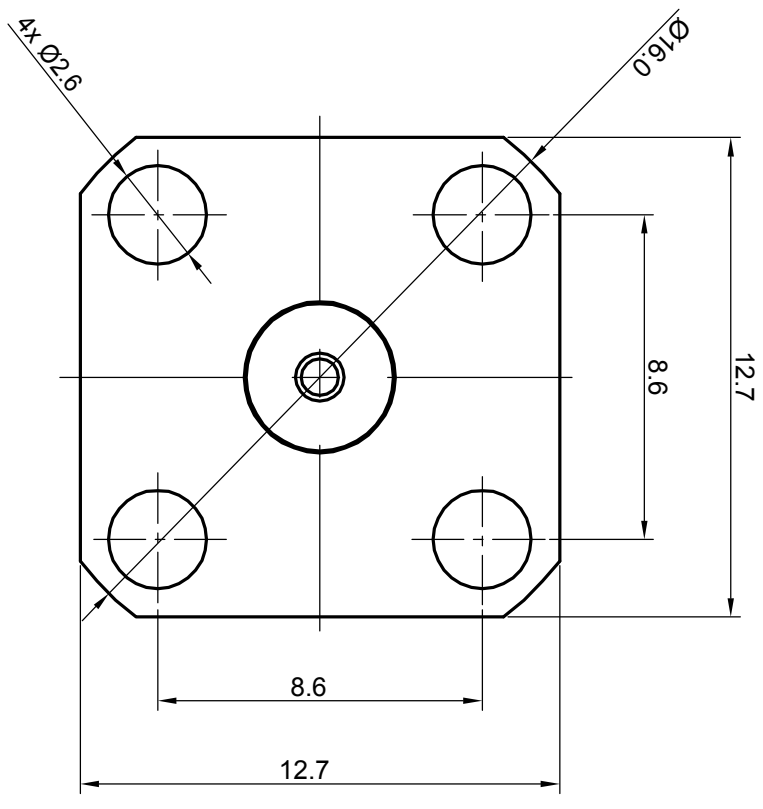

NOTES: (UNLESS OTHERWISE SPECIFIED)

1. INTERFACE COMPLY WITH IEC 169-15.
2. PART MUST BE PACKAGED TO AVOID ANY DAMAGES DURING TRANSPORTATION.

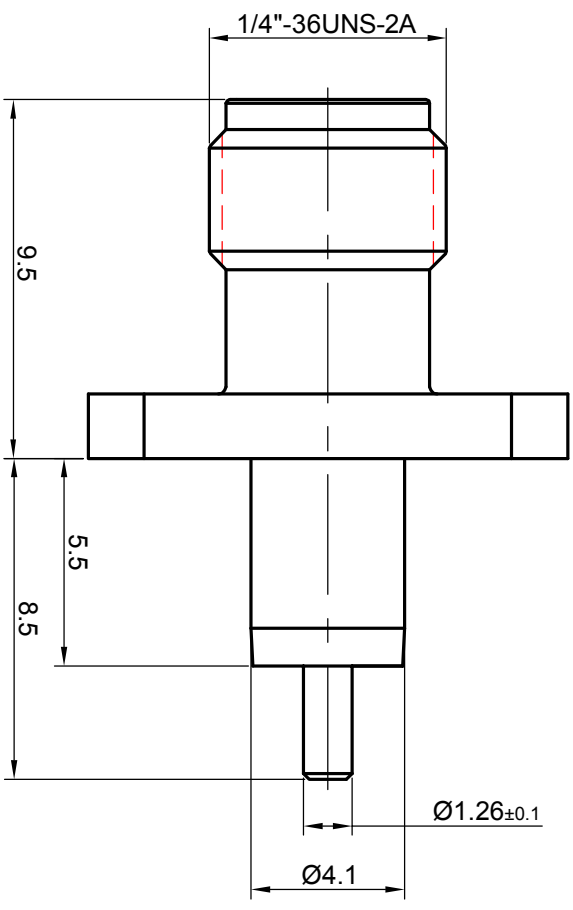

REV.	DESCRIPTION	APPROVED	DATE	ECN

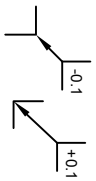
MATERIAL SEE BOM FOR DETAILS		TOLERANCES		THIRD ANGLE PROJECTION		TITLE	
FINISH SEE BOM FOR DETAILS		Opface X ±1	1place X ±0.1	GENERAL ECCENTRICITY <input checked="" type="checkbox"/> 0.06		 SMA, JACK, FLANGE	
Dimension apply before plating		2place XX ±0.05	Angle ±5°	NAME	DATE		
Plating part to be touched by gloves		Remove burrs and sharp edges		DRAWN BY	Colin	22Aug07	DWG NO.
XXX - measuring point for plating				CHECKED BY			5971.SMA.JSF.00.110
SURFACE		SURFACE		APPROVED BY			REV.
VOLUME		VOLUME		SCALE		5:1	DO NOT SCALE DRAWING
				SIZE		A4	SHEET
							1 of 1

NOTICE: Those drawings and specifications are the property of ZEETEQ CORPORATION and used only for the specify purpose authorised by ZEETEQ