

NOTES: (UNLESS OTHERWISE SPECIFIED)

1. Interface according to IEC 169-15
2. With a protective cap.
3. Part must be packaged to avoid any damages during transportation.

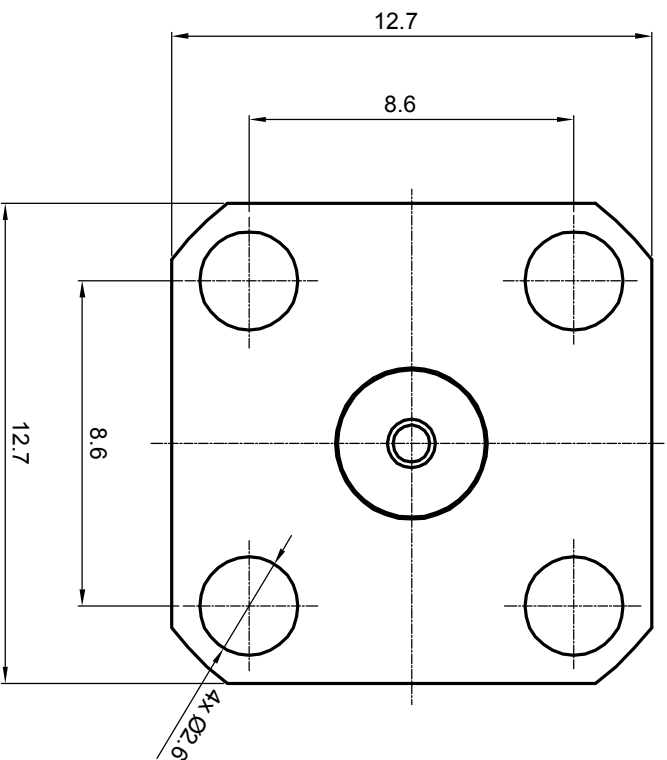
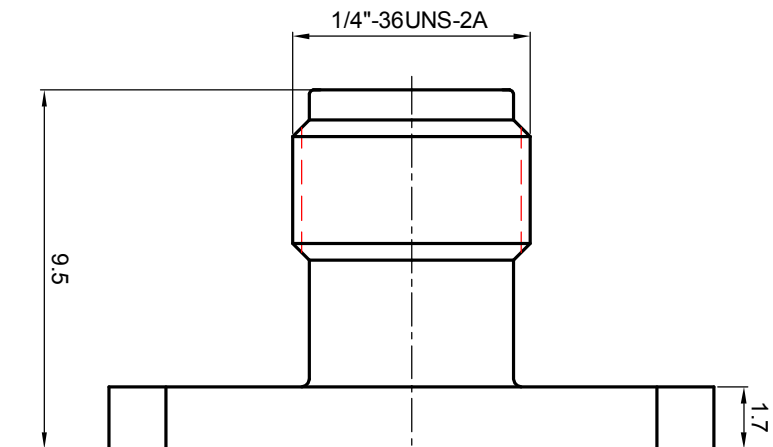

REV.	DESCRIPTION	APPROVED	DATE	EON

MATERIAL SEE BOM		TOLERANCES 0place X ±1 1place X ±0.1 2place XX ±0.05 Angle ±5°		THIRD ANGLE PROJECTION 		TITLE Zeeteq	
FINISH SEE BOM		Remove burrs and sharp edges 		GENERAL ECCENTRICITY $\sqrt[3]{1008}$		DWG NO. 5976.SMA.JSF.00.110	
SEE BOM Plating part to be touched by gloves Dimension apply before plating XXX - measuring point for plating		DRAWN BY Coin		NAME Coin		DATE 21Mar08	
SURFACE		CHECKED BY		APPROVED BY		SCALE 2:1	
VOLUME		NOTICE: Those drawings and specifications are the property of ZEETEQ CORPORATION and used only for the specify purpose authorised by ZEETEQ				DO NOT SCALE DRAWING	
						SIZE A4	
						SHEET 1 of 1	
						REV. S1	

1 2 3 4 5 6

D C B A