

**NOTES: (UNLESS OTHERWISE SPECIFIED)**

1. Interface according to IEC 169-15
2. With a protective cap.
3. Part must be packaged to avoid any damages during transportation.

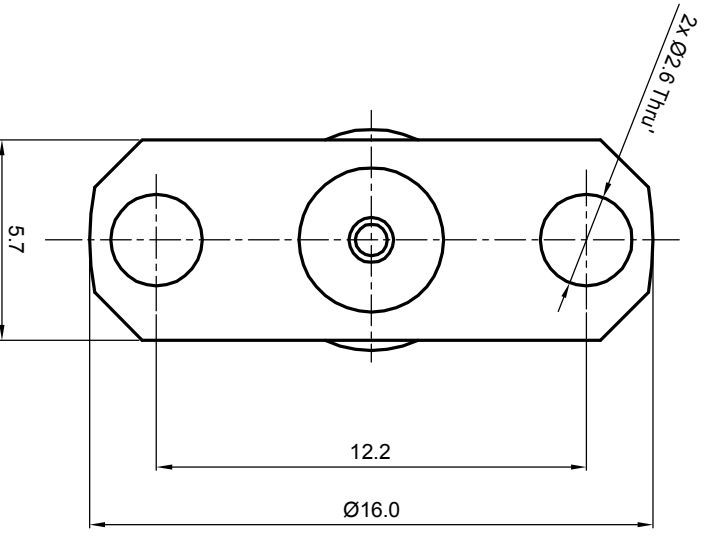
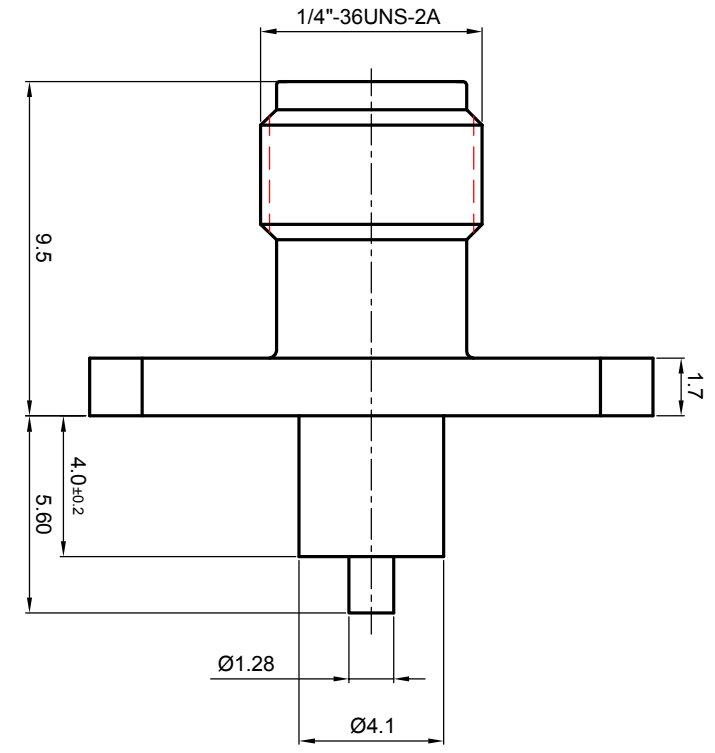

REV.	DESCRIPTION	APPROVED	DATE	ECN
A	Rel to production	Johnny	23Oct07	

MATERIAL		TOLERANCES		THIRD ANGLE PROJECTION		TITLE	
SEE BOM		Oplate X ±1 1place X ±0.1 2place .XX ±0.05 Angle ±5°					
FINISH		Remove burrs and sharp edges		GENERAL ECCENTRICITY		DWG NO.	
SEE BOM				[Z1028]		6080.SMA.JSF.00.110	
Plating part to be touched by gloves		DRAWN BY		NAME		SMA, JACK, FLANGE	
Dimension apply before plating		Collin		DATE		08Oct07	
XXX - measuring point for plating		CHECKED BY		APPROVED BY		REV.	
SURFACE		VOLUME		NOTICE: Those drawings and specifications are the property of ZEETEQ CORPORATION and used only for the specify purpose authorised by ZEETEQ		SCALE	
						2:1	
						DO NOT SCALE DRAWING	
						SIZE	
						A4	
						SHEET	
						1 of 1	

