

NOTES: (UNLESS OTHERWISE SPECIFIED)

1. Interface comply with IEC 169-15.
2. Part must be packaged to avoid any damages during transportation.
3. With a protective cap.

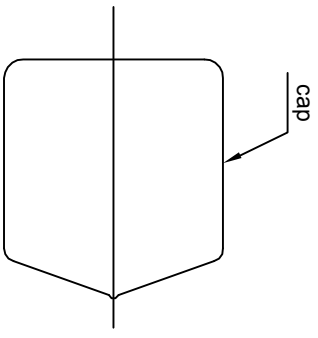
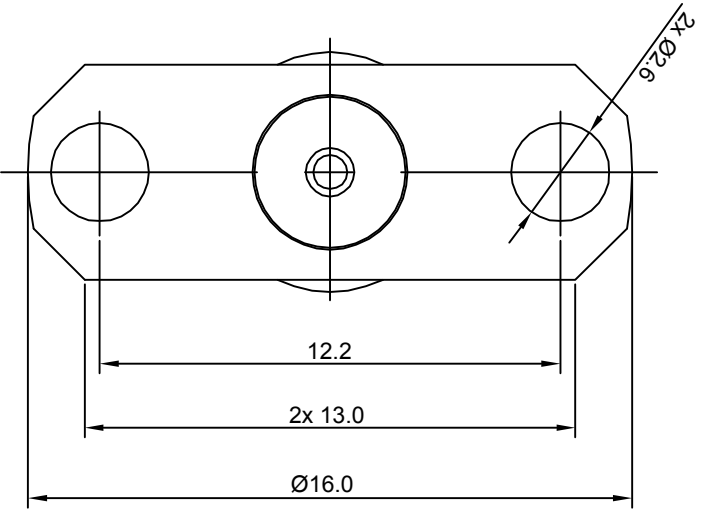
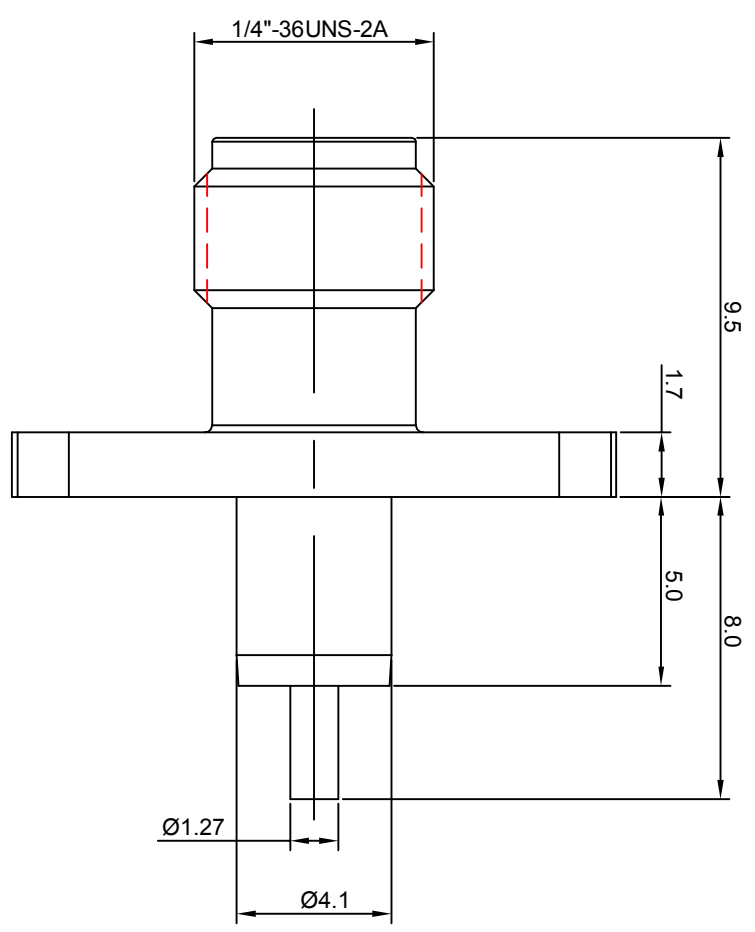

REV.	DESCRIPTION	APPROVED	DATE	ECN

MATERIAL		SEE BOM FOR DETAILS
FINISH		SEE BOM FOR DETAILS
Plating part to be touched by gloves		
Dimension apply before plating		
XXX - measuring point for plating		
SURFACE	VOLUME	

TOLERANCES		
Opface	X ±1	
1place	.X ±0.1	
2place	.XX ±0.05	
Angle	±5°	
Remove burrs and sharp edges		
	-0.2	
	+0.2	

THIRD ANGLE PROJECTION		
GENERAL ECCENTRICITY		√ 0.06
DRAWN BY	NAME	DATE
Colin	Colin	17Dec07
CHECKED BY		
APPROVED BY		

NOTICE: Those drawings and specifications are the property of ZEETEQ CORPORATION and used only for the specify purpose authorised by ZEETEQ

TITLE		Zee-teq	
SMA, JACK, FLANGE			
DWG.NO.	6115.SMA.JSF.00.110	REV.	S1
SCALE	5:1	DO NOT SCALE DRAWING	
SIZE	A4	SHEET	1 of 1