

NOTES: (UNLESS OTHERWISE SPECIFIED)

1. Mating according to IEC169-36.
2. With a protective cap.
3. Part must be packaged to avoid any damages during transportation.

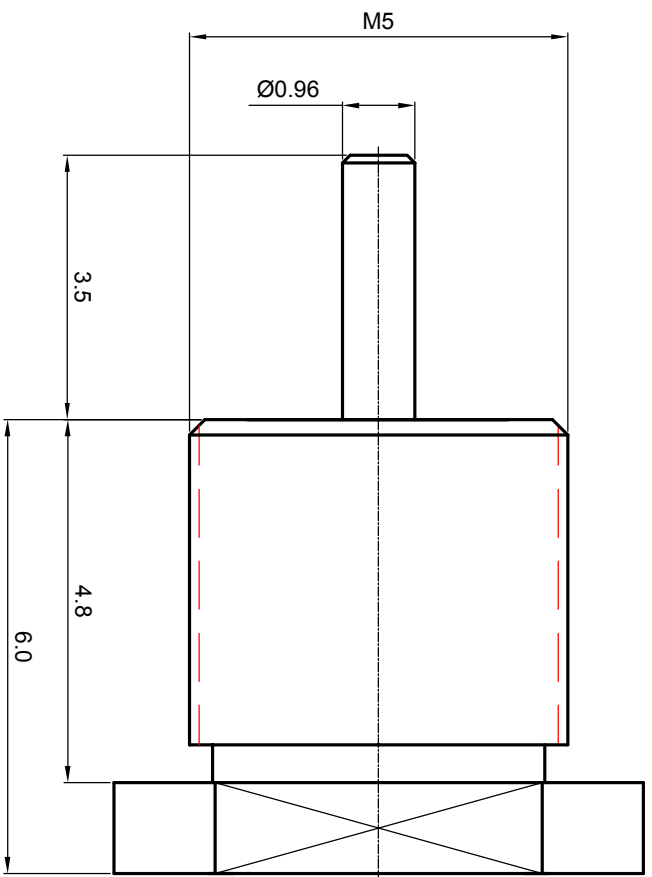
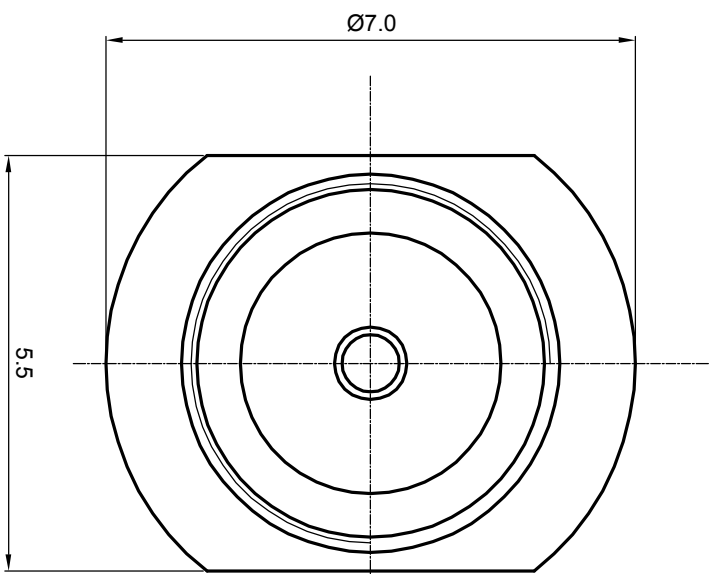

REV.	DESCRIPTION	APPROVED	DATE	EEN

MATERIAL SEE BOM		TOLERANCES		THIRD ANGLE PROJECTION		TITLE	
FINISH SEE BOM		Oplate X ±1 1place X ±0.1 2place XX ±0.05 Angle ±5°				Zeeteq MCX, JACK, BULKHEAD	
Plating part to be touched by gloves Dimension apply before plating XXX - measuring point for plating		Remove burrs and sharp edges 		GENERAL ECCENTRICITY <input checked="" type="checkbox"/> 100%		DWG NO. 6092.MCX.JSB.00.110	
SURFACE		DRAWN BY Colin		NAME Colin		DATE 05Nov07	
VOLUME		CHECKED BY		APPROVED BY		REV. S1	
SCALE 10:1		DO NOT SCALE DRAWING		SIZE A4		SHEET 1 of 1	

NOTICE: Those drawings and specifications are the property of ZEETEQ CORPORATION and used only for the specify purpose authorised by ZEETEQ