

NOTES: (UNLESS OTHERWISE SPECIFIED)

1. Mating according to MIL-STD-348A.

REV.	DESCRIPTION	APPROVED	DATE	ECN

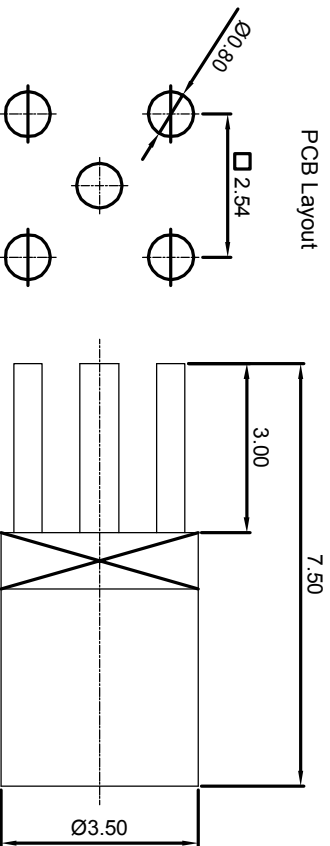

1.6

MATERIAL SEE BOM		TOLERANCES 1place X ±1 2place .XX ±0.05 Angle ±5°		THIRD ANGLE PROJECTION GENERAL ECCENTRICITY <input checked="" type="checkbox"/> 0.06		TITLE Zeeteq	
FINISH SEE BOM		Remove burrs and sharp edges -0.1 +0.1		DRAWN BY Joy Zhou CHECKED BY APPROVED BY		DWG NO. 5983.MMCX.JRT.00.110	
Plating part to be touched by gloves Dimension apply before plating XXX - measuring point for plating		NOTICE: Those drawings and specifications are the property of ZEETEQ CORPORATION and used only for the specify purpose authorised by ZEETEQ		NAME DATE 25Mar08		SCALE 8:1 DO NOT SCALE DRAWING	
SURFACE		VOLUME		SIZE A4		SHEET 1 of 1	