

NOTES: (UNLESS OTHERWISE SPECIFIED)

1. The interface comply with MIL-STD-348A.

Recommended
Mounting hole

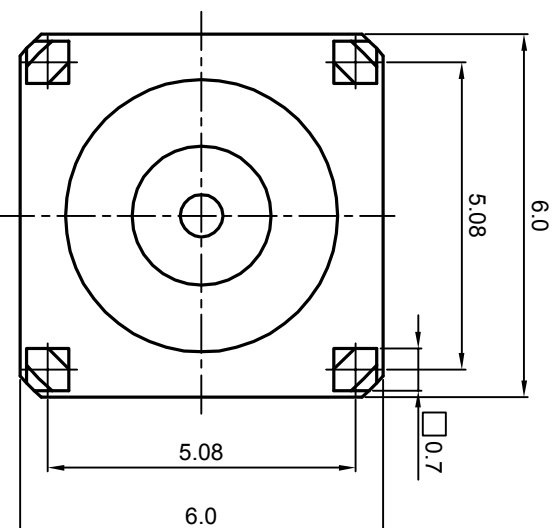
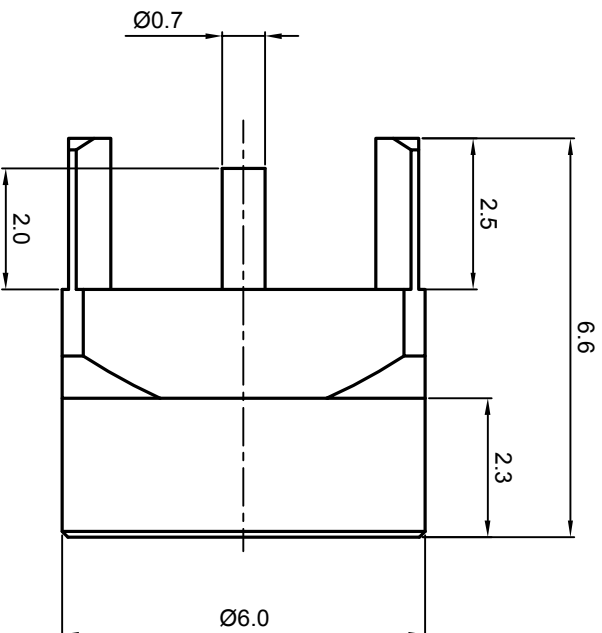
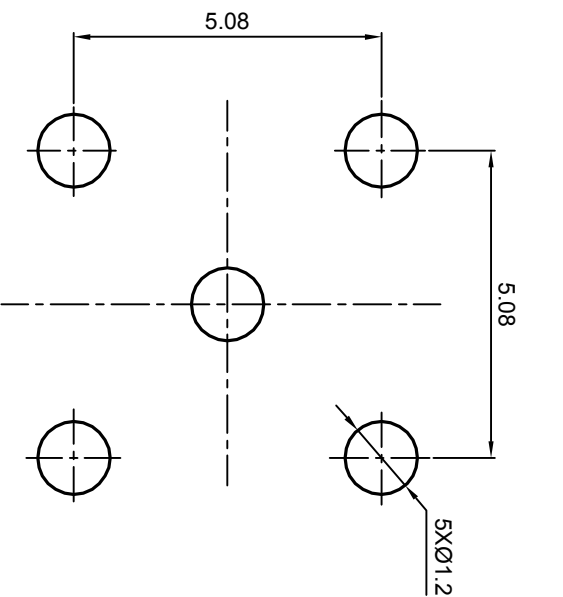

1.6

REV.	DESCRIPTION	APPROVED	DATE	EON

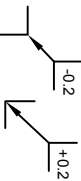
MATERIAL SEE BOM FOR DETAILS		TOLERANCES Oplace X ±1 1place X ±0.1 2place XX ±0.05 Angle ±5°		THIRD ANGLE PROJECTION 		TITLE Zeeteq	
FINISH SEE BOM FOR DETAILS		Remove burrs and sharp edges 		GENERAL ECCENTRICITY <input checked="" type="checkbox"/> 0.06		DWG NO. 5990.SMP.PST.00.110	
Plating part to be touched by gloves		DRAWN BY Danny.D		NAME DATE		REV. S1	
Dimension apply before plating		CHECKED BY		APPROVED BY		SCALE 8:1	
XXX - measuring point for plating		SURFACE		VOLUME		DO NOT SCALE DRAWING	
						SIZE A4	
						SHEET 1 of 1	

1 2 3 4 5 6

A B C D