

NOTES: (UNLESS OTHERWISE SPECIFIED)

1. Interface comply with IEC 169-10.
 2. Part must be packaged to avoid any damaged during transportation.
- A** After crimping dimension should be AF/SW 3.25.

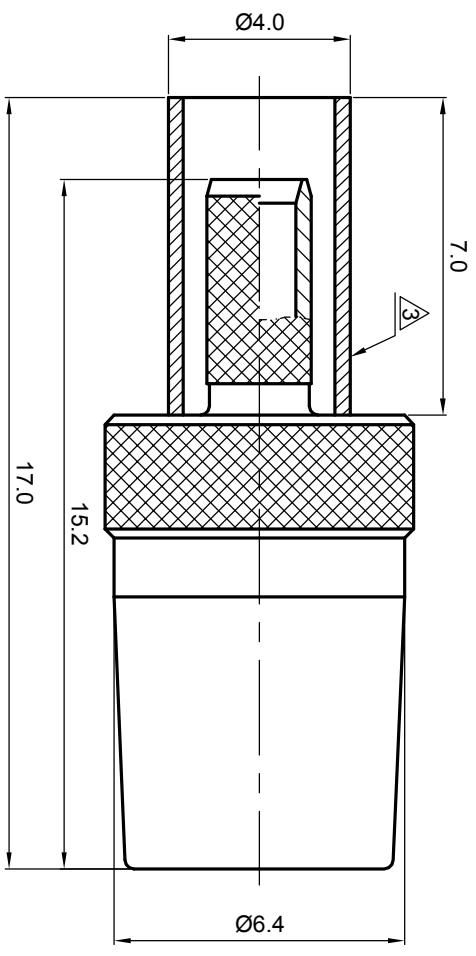

Recommended cable stripping dims

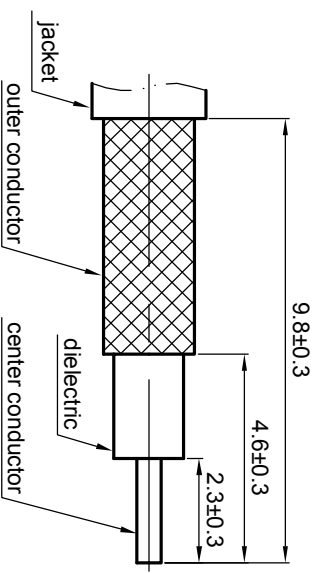

REV.	DESCRIPTION	APPROVED	DATE	EON

MATERIAL		SEE BOM OF DETAILS		TOLERANCES		THIRD ANGLE PROJECTION		TITLE	
SEE BOM OF DETAILS		SEE BOM OF DETAILS		Opface X ±1 1place X ±0.1 2place XX ±0.05 Angle ±5°				Zeeteq SMB,jack, cable	
FINISH		REMOVE BURRS AND SHARP EDGES		Remove burrs and sharp edges 		GENERAL ECCENTRICITY <input checked="" type="checkbox"/> 0.06		DWG NO. 5149.SMB.JSC.07.111	
SEE BOM OF DETAILS		Plating part to be touched by gloves Dimension apply before plating XXX - measuring point for plating		DRAWN BY Billy CHECKED BY APPROVED BY		NAME DATE 9 Nov 07		SCALE 6:1 DO NOT SCALE DRAWING SIZE A4	
SURFACE		VOLUME		NOTICE: Those drawings and specifications are the property of ZEETEQ CORPORATION and used only for the specify purpose authorised by ZEETEQ		REV. S1		SHEET 1 of 1	

