

- NOTES: (UNLESS OTHERWISE SPECIFIED)**
- Interface comply with IEC 61169-36.
  - Part must be packaged to avoid any damaged during transportation.

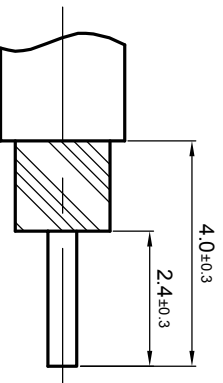

Recommended cable stripping dirms

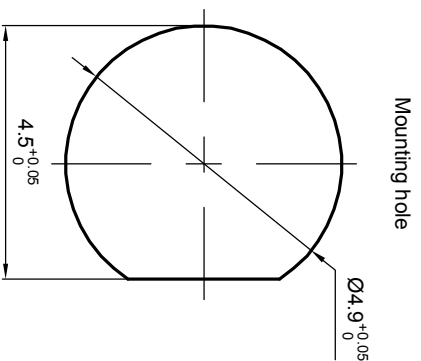
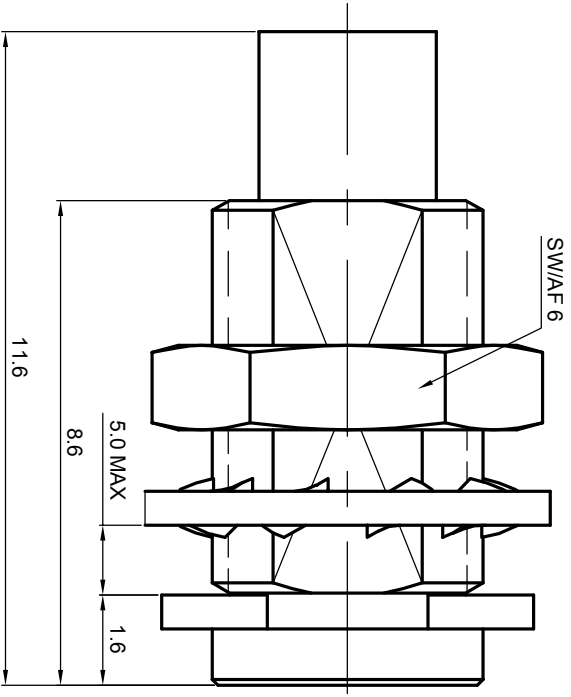

REV.	DESCRIPTION	APPROVED	DATE	EON
A	Rel To Production	Johnny	11Aug08	EON_08_045

MATERIAL		TOLERANCES		THIRD ANGLE PROJECTION		TITLE	
SEE BOM OF DETAILS		Oplate X ±1 1place X ±0.1 2place .XX ±0.05 Angle ±5°				<b>Zeeteq</b> MCX,jack,cable	
SEE BOM OF DETAILS		Remove burrs and sharp edges		GENERAL ECCENTRICITY <input checked="" type="checkbox"/> 0.06 DRAWN BY Joy zhou CHECKED BY APPROVED BY		DWG NO. 5099.MCX.JSC.02.111 SCALE 8:1 DO NOT SCALE DRAWING SIZE A4	
FINISH		Plating part to be touched by gloves Dimension apply before plating XXX - measuring point for plating		NOTICE: Those drawings and specifications are the property of ZEETEQ CORPORATION and used only for the specify purpose authorised by ZEETEQ		REV. A SHEET 1 of 1	
SURFACE		VOLUME					

