

NOTES: (UNLESS OTHERWISE SPECIFIED)

1. Interface comply with IEC 169-16.
2. Part must be packaged to avoid any damaged during transportation.

A After crimping dimension should be AF/SW 5.41.

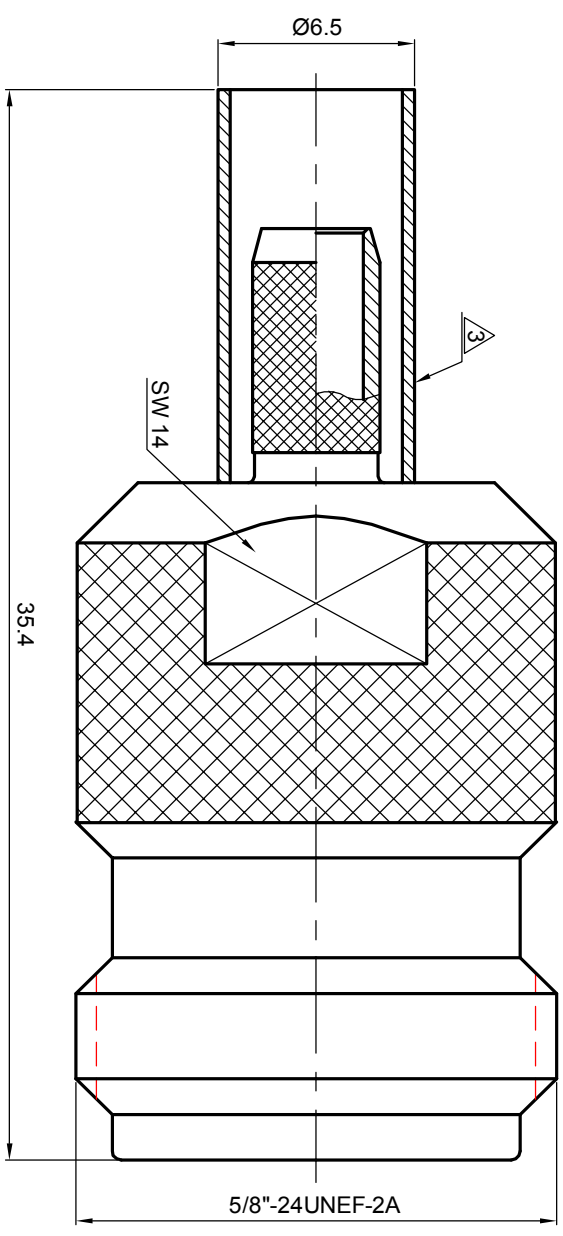

recommended cable stripping dims

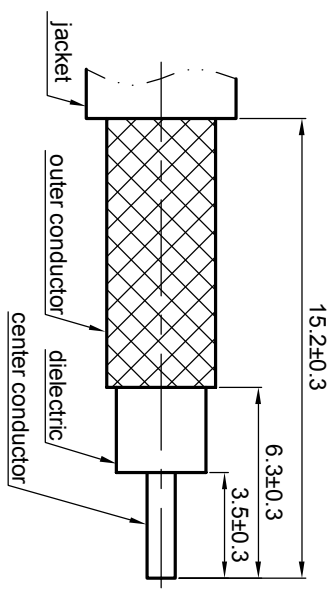

MATERIAL		SEE BOM OF DETAILS		TOLERANCES		THIRD ANGLE PROJECTION		TITLE	
SEE BOM OF DETAILS		SEE BOM OF DETAILS		Opface X ±1 1place .X ±0.1 2place .XX ±0.05 Angle ±5°		GENERAL ECCENTRICITY <input checked="" type="checkbox"/> 0.06		Zeeteq N,jack, cable	
FINISH		REMOVE BURRS AND SHARP EDGES		-0.2 +0.2		DRAWN BY Billy CHECKED BY APPROVED BY		DWG NO. 5212.N.JSC.09.133	
SEE BOM OF DETAILS		Plating part to be touched by gloves Dimension apply before plating XXX - measuring point for plating		NOTICE: Those drawings and specifications are the property of ZEETEQ CORPORATION and used only for the specify purpose authorised by ZEETEQ		NAME DATE 190c107		SCALE 3:1 DO NOT SCALE DRAWING	
SURFACE		VOLUME						SIZE A4 SHEET 1 of 1	

1.6

REV.	DESCRIPTION	APPROVED	DATE	ECN