

**NOTES: (UNLESS OTHERWISE SPECIFIED)**

1. Interface comply with IEC 169-16.
2. Part must be packaged to avoid any damaged during transportation.

A After crimping dimension should be AF/SW 5.41.

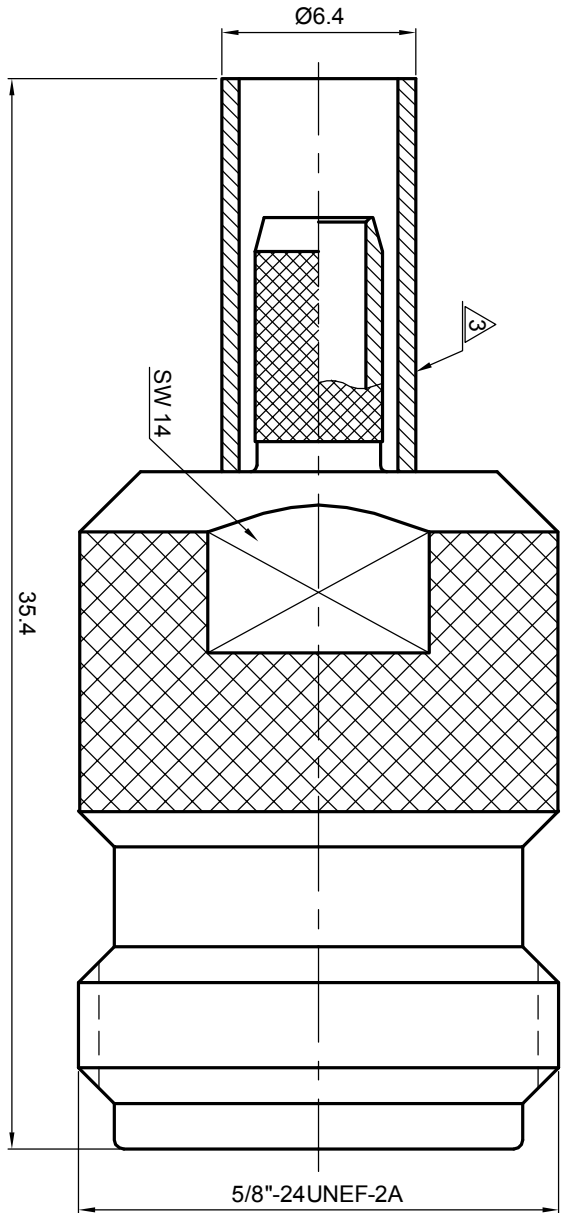

recommended cable stripping dims

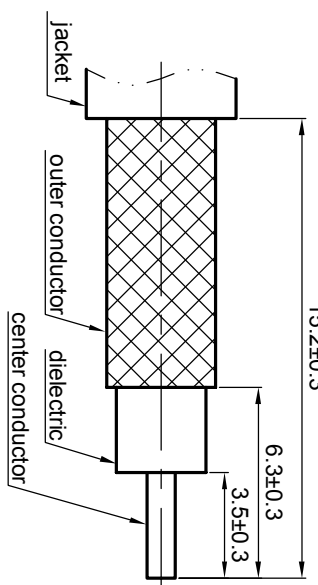

REV.	DESCRIPTION	APPROVED	DATE	ECN

MATERIAL		SEE BOM OF DETAILS		TOLERANCES		THIRD ANGLE PROJECTION		TITLE	
SEE BOM OF DETAILS		SEE BOM OF DETAILS		Opface X ±1 1place X ±0.1 2place XX ±0.05 Angle ±5°				<b>Zee-teq</b> N,jack, cable	
FINISH		REMOVE BURRS AND SHARP EDGES		Remove burrs and sharp edges 		GENERAL ECCENTRICITY  0.06		DWG NO. 5211.N.JSC.08.133	
SEE BOM OF DETAILS		Plating part to be touched by gloves Dimension apply before plating XXX - measuring point for plating		DRAWN BY Billy CHECKED BY APPROVED BY		NAME DATE 190c107		SCALE 3:1 DO NOT SCALE DRAWING	
SURFACE		VOLUME		NOTICE: Those drawings and specifications are the property of ZEEITEQ CORPORATION and used only for the specify purpose authorised by ZEEITEQ		SIZE A4		SHEET 1 of 1	

1.6