

**NOTES: (UNLESS OTHERWISE SPECIFIED)**

1. Interface comply with IEC 169-16.
2. Part must be packaged to avoid any damaged during transportation.

**A** After crimping dimension should be AF/SW 5.41.

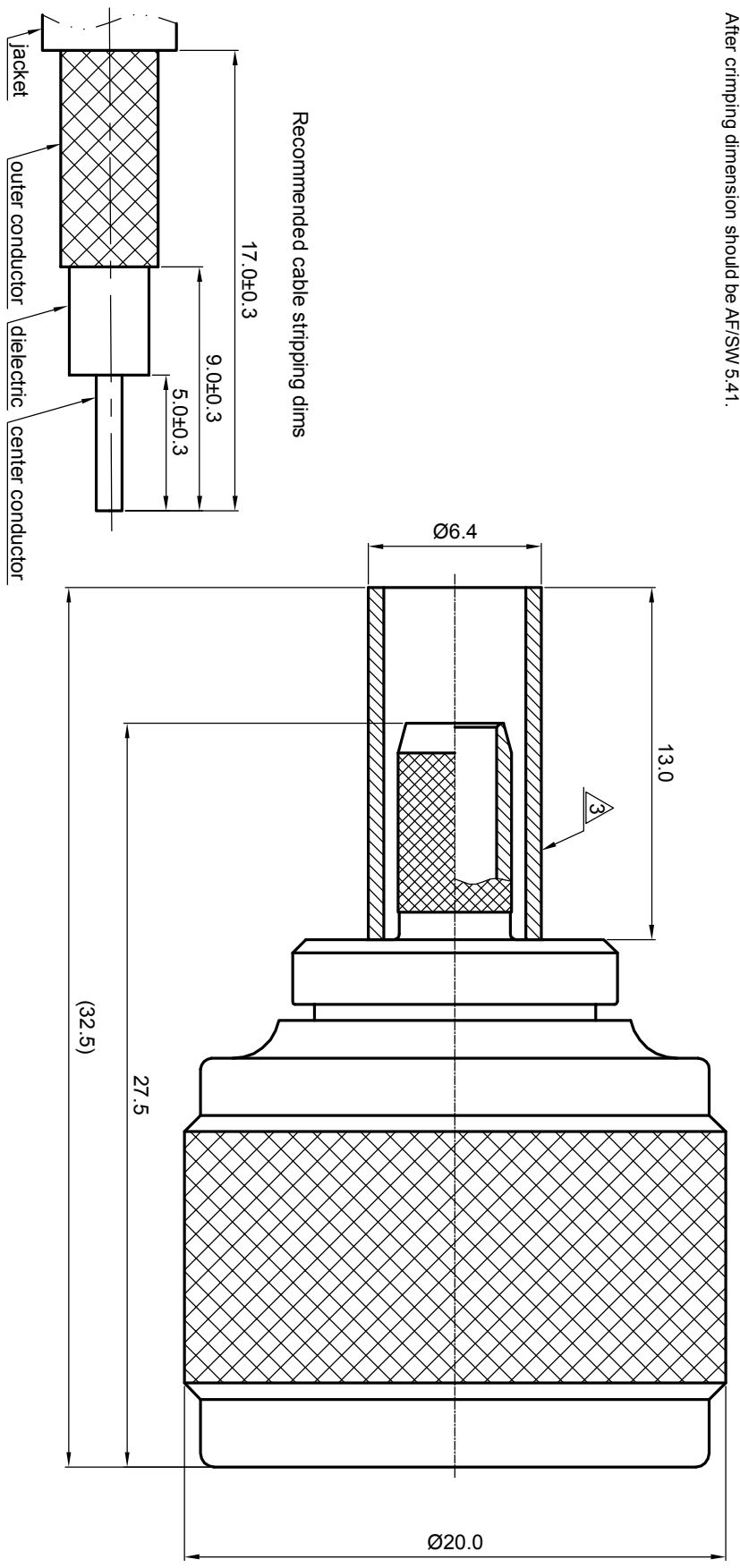

REV.	DESCRIPTION	APPROVED	DATE	ECN
A	REL. TO PRODUCTION	Johnny	28 Nov 07	

MATERIAL		SEE BOM OF DETAILS		TOLERANCES		THIRD ANGLE PROJECTION		TITLE	
SEE BOM OF DETAILS		SEE BOM OF DETAILS		Opface X ±1 1place X ±0.1 2place XX ±0.05 Angle ±5°				<b>Zee-teq</b> N, plug, cable	
FINISH		Remove burrs and sharp edges		-0.2 +0.2		GENERAL ECCENTRICITY <input checked="" type="checkbox"/> 0.06		DWG NO.	
SEE BOM OF DETAILS		Plating part to be touched by gloves Dimension apply before plating XXX - measuring point for plating		NOTICE: Those drawings and specifications are the property of ZEE-TEQ CORPORATION and used only for the specify purpose authorised by ZEE-TEQ		DRAWN BY Billy Lei 20 Nov 07 CHECKED BY Joy 28 Nov 07 APPROVED BY Johnny 28 Nov 07		5040.N.PSC.08.133	
SURFACE		VOLUME				SCALE		REV.	
						4:1		A	
						DO NOT SCALE DRAWING		SHEET	
								1 of 1	

