

NOTES: (UNLESS OTHERWISE SPECIFIED)

- Interface comply with IEC 169-16.
 - Part must be packaged to avoid any damaged during transportation.
- After crimping dimension should be AF/SW 3.25.

REV.	DESCRIPTION	APPROVED	DATE	ECN
A	REL. TO PRODUCTION	Johnny	10Dec07	

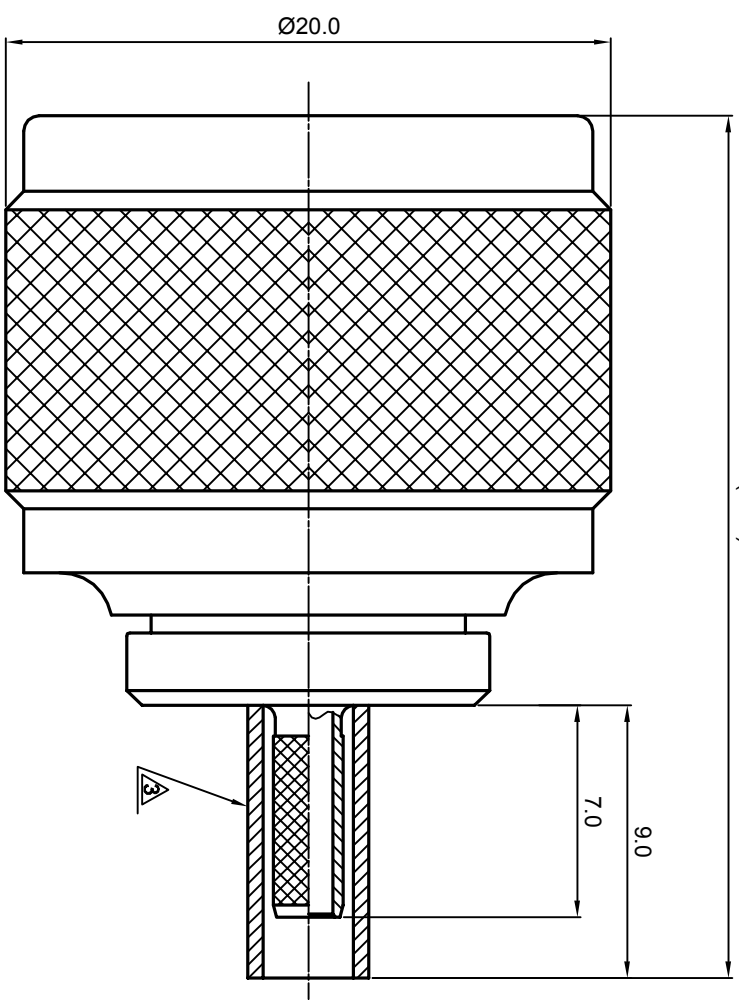

RECOMMENDED CABLE STRIPPING DIMENSIONS

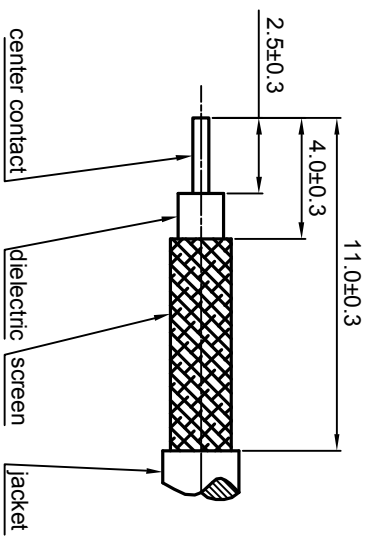

MATERIAL		SEE BOM FOR DETAILS		TOLERANCES		THIRD ANGLE PROJECTION		TITLE	
FINISH		SEE BOM FOR DETAILS		Opface X ±1 1place X ±0.1 2place XX ±0.05 Angle ±5°				Zee-teq N, PLUG, CABLE MOUNT	
Plating part to be touched by gloves				Remove burrs and sharp edges		DRAWN BY Danny 17Oct07 CHECKED BY Colin 11Dec07 APPROVED BY Johnny 11Dec07		DWG. NO. 5038.N.PRC.06.133 REV. A	
Dimension apply before plating						NAME DATE Danny 17Oct07 Colin 11Dec07 Johnny 11Dec07		SCALE 4:1 DO NOT SCALE DRAWING SIZE A4 SHEET 1 of 1	
XXX - measuring point for plating				NOTICE: Those drawings and specifications are the property of ZEE-TEQ CORPORATION and used only for the specify purpose authorised by ZEE-TEQ					
SURFACE		VOLUME							

1.6