

1

2

3

4

5

6

NOTES: (UNLESS OTHERWISE SPECIFIED)

- 1. Interface according to IEC169-16.
- 2. Part must be packaged to avoid any damages during transportation.

REV.	DESCRIPTION	APPROVED	DATE	EON
A	Rel to production	Johnny	14Dec07	

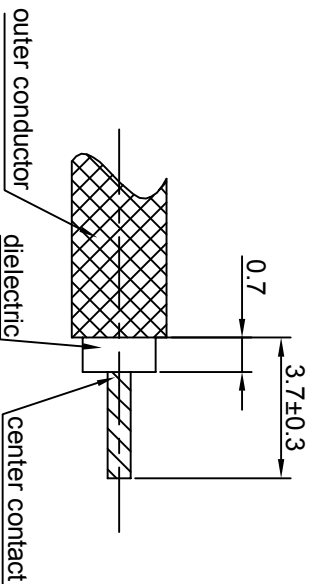
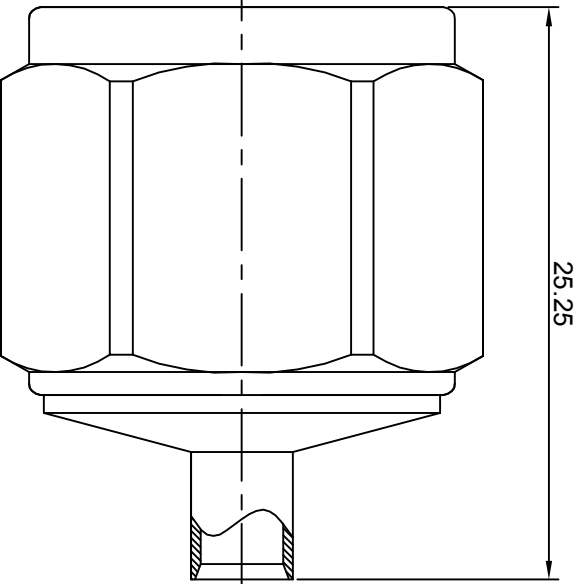

MATERIAL SEE BOM FOR DETAILS		TOLERANCES Opface X ±1 1place .X ±0.1 2place XX ±0.05 Angle ±5°		THIRD ANGLE PROJECTION 		TITLE Zeeteq	
FINISH SEE BOM FOR DETAILS		Remove burrs and sharp edges 		GENERAL ECCENTRICITY <input checked="" type="checkbox"/> 0.06		DWG. NO. 5036.N. PSC.03.133	
Plating part to be touched by gloves		DRAWN BY Collin		DATE 03Aug07		REV. A	
Dimension apply before plating		CHECKED BY				SCALE 3:1	
XXX - measuring point for plating		APPROVED BY				DO NOT SCALE DRAWING	
SURFACE		VOLUME				SIZE A4	
						SHEET 1 of 1	



A B C D

A B C D

1

2

3

4

5

6